



# XECC-0513-EPLM

Project	_____
Item	_____
Quantity	_____
Date	_____

### Model

**CHEFTOP MIND.Maps™ PLUS COMPACT**

**Energy efficiency 21.6 kWh/day - 0 kg CO<sub>2</sub>/day\***

\*More details on the last page.

Combi oven	Electric
5 trays GN 1/1	Hinge on the right side
9.5" Touch control panel	
Voltage:	380-415V 3N~ / 220-240V 3~ / 220-240V 1N~

### Description

Technologically advanced combi oven for gastronomy cooking processes (dehydrating, steaming, low temperature cooking, sous vide cooking, roasting, grilling, pan frying, regeneration and plate regeneration) and for fresh or frozen baking thanks to Unox Intensive Cooking and Intelligence Performance technologies which guarantee perfect results and repeatability for any load size. Automatic management of cooking processes (CHEFUNOX) for perfect results even without trained staff.



### Standard cooking features

#### Programs

- **1000+** Programs
- **CHEFUNOX**: choose something to cook from the library and the oven will automatically set all the parameters
- **MULTI.TIME**: manages up to 10 cooking processes at the same time
- **MISE.EN.PLACE**: synchronises the insertion of pans so that all the dishes are ready at the same time
- **MIND.Maps™**: draw the cooking processes directly on the display
- **READY.COOK**: ready to use settings with infinite time for a quick start

#### Manual cooking

- **Temperature**: 30 °C – 260 °C
- Up to 9 cooking steps
- **CLIMA.Control**: humidity or dry air set by 10%
- Delta T cooking with core probe
- **MULTI.Point** core probe with 4 measuring points
- **SOUS-VIDE** core probe with 2 measuring points (optional accessory)

### Advanced and automatic cooking features

#### Unox Intelligent Performance

- **ADAPTIVE.Cooking™**: automatically regulates the cooking parameters to ensure repeatable results
- **CLIMALUX™**: total control of the humidity in the cooking chamber
- **SMART.Preheating**: automatically sets the preheating temperature and duration
- **AUTO.Soft**: manages the heat rise to make it more delicate
- **SENSE.Klean**: estimates how dirty the oven is and suggests the appropriate automatic washing cycle

#### Unox Intensive Cooking

- **DRY.Maxi™**: rapidly extracts the humidity from the cooking chamber
- **STEAM.Maxi™**: produces saturated steam
- **AIR.Maxi™**: manage fans auto-reverse and pulse function
- **PRESSURE.Steam**: increases the steam saturation and temperature



# XECC-0513-EPLM

## Key features

- **ROTOR.Klean™**: automatic washing system
- Automatic special washing behind the fan guard
- Cooking chamber in high-resistance AISI 304 stainless steel with rounded edges
- Triple glass
- Cooking chamber lighting through LED lights embedded in the door
- Tray supports with anti-tip system
- Drip collection system integrated in the door which works even when the door is open
- 4-speed fan system and high-performance heating elements
- Integrated DET&Rinse™ detergent container
- Integrated Wi-Fi
- **Wi-Fi / USB data**: download/upload HACCP data
- **Wi-Fi / USB data**: download/upload programs

## App and web services

- **Data Driven Cooking app & webapp**: check and monitor in real-time the operating conditions of your ovens, create and share new recipes. Artificial intelligence transforms consumption data into useful information and allows you to increase daily profits
- **Top Training app**: download the Unox Top.Training app and learn step by step all the secrets of your new oven's control panel

## Accessories

- **Ventless hood**: steam condensing hood
- **Ventless hood with activated carbon filter**: steam condensing hood with activated carbon filter
- **Neutral cabinet**: recommended solution to optimize your kitchen layout and always have everything in the right place
- **Stand**: the multifunctional support ideal for storing trays safely and placing your oven at the perfect height to work
- **QUICK.Load** and trolley system
- **Cooking Essentials**: special trays
- **DET&Rinse™ ECO**: eco formula for daily cleaning and the utmost respect for the environment. Ideal for mild level of dirt.
- **DET&Rinse™ ULTRAPLUS**: cleaning and rinse agents to combine maximum cleanliness with minimum consumption and long life for your oven
- **PURE / PURE.XL**: resin-based filtering system that eliminates from the water all substances that contribute to the formation of limescale inside the oven cooking chamber
- **PURE-RO**: Reverse osmosis system that eliminates Chlorides and limescale from water
- Ethernet connection kit

# XECC-0513-EPLM

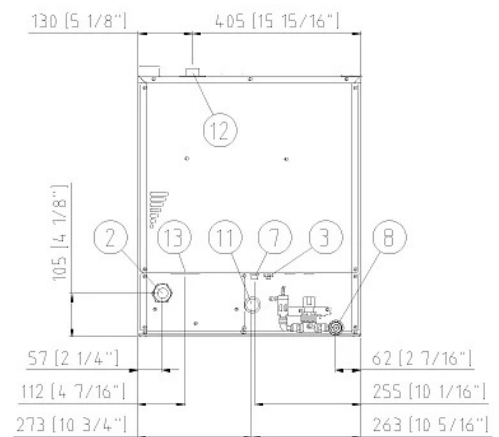
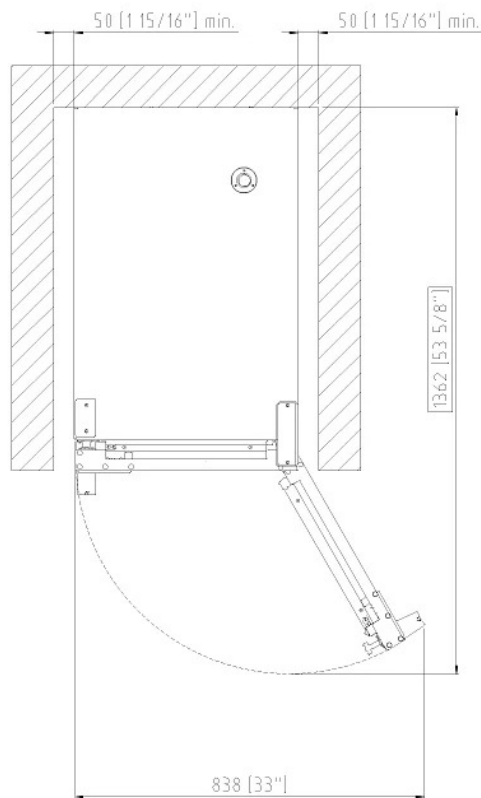
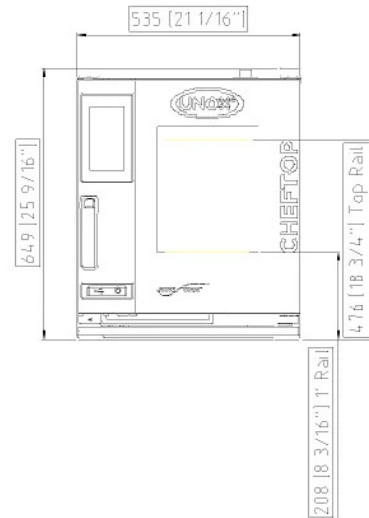
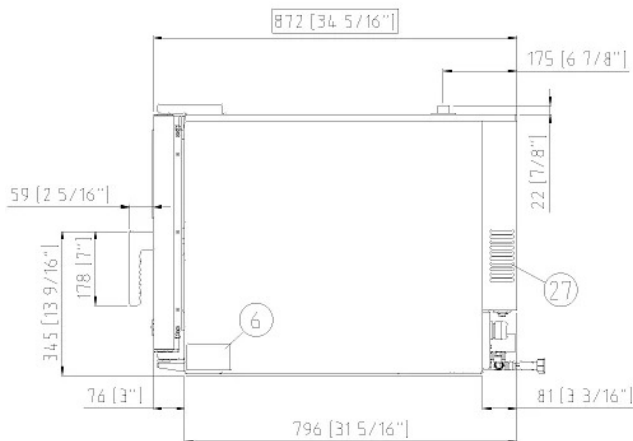

## Dimensions and weight

Width	535 mm
Depth	872 mm
Height	649 mm
Net weight	68 kg
Tray pitch	67 mm

## Connection positions

2	Terminal board power supply
3	Unipotential terminal
6	Technical data plate
7	Safety thermostat
8	3/4" female NPT water inlet
10	Rotor.KLEAN™ inlet

11	Chamber drain pipe
12	Hot fumes exhaust chimney
13	Accessories connection
27	Cooling air outlet



# XECC-0513-EPLM

## Electrical power supply

### STANDARD

Voltage	380-415 V
Phase	~3PH+N+PE
Frequency	50 / 60 Hz
Total power	9,3 kW
Max Amp draw	14 A
Required breaker size	20 A
Power cable requirements*	5G x 2,5 mm <sup>2</sup>
Plug	NOT INCLUDED

### OPTION A

Voltage	220-240 V
Phase	~3PH+PE
Frequency	50 / 60 Hz
Total power	9,3 kW
Max Amp draw	23 A
Required breaker size	25 A
Power cable requirements*	4G x 4 mm <sup>2</sup>
Plug	NOT INCLUDED

### OPTION B

Voltage	220-240 V**
Phase	~1PH+N+PE
Frequency	50 / 60 Hz
Total power	9,3 kW
Max Amp draw	41 A
Required breaker size	50 A
Power cable requirements*	3G x 10 mm <sup>2</sup>
Plug	NOT INCLUDED

### \*\*Electric connection kit

Item	XUC129
Voltage	220-240 V
Phase	~1PH+N+PE

\*Recommended size - observe local ordinance.

## Energy efficiency

### Consumption

### CO<sub>2</sub> emission

\*\*The estimate includes only direct emissions produced by the oven. Indirect emissions can be reduced to zero by choosing to purchase energy from renewable sources.

### Estimate based on daily use of the oven (300 days/year):

6 light loads of roast chickens (loaded at 20%), 1 full load of roast potatoes, 3 full loads cooking with steam 2 hours in an empty oven at 180 °C.

### Estimated assuming the following weekly washing programs (42 weeks/year):

1 long wash, 1 medium wash.

## Water Supply

USING A WATER SUPPLY THAT DOES NOT MEET UNOX'S MINIMUM WATER QUALITY STANDARDS WILL VOID ANY WARRANTY.

It is the responsibility of the purchaser to ensure that the incoming water supply is compliant with the listed specifications through adequate treatment measures.

**Line pressure:** Drinking water inlet: 3/4" NPT\*, line pressure: 22 to 87 psi; 1.5 to 6 Bar (29 psi; 2 Bar recommended)

### Inflow water specifications

**Free chlorine** ≤ 0.5 ppm

**Chloramine** ≤ 0.1 ppm

**pH** 7 - 8.5

**Electrical conductivity** ≤ 1000 µS/cm

**Total hardness** ≤ 30° dH

**Chlorides** ≤ 120 ppm

### Steam circuit: inflow water specifications

**Total hardness** ≤ 8 °dH

**Chlorides** ≤ 25 ppm

To avoid the formation of limescale the incoming water must have total hardness ≤ 8°dH.

\*This value refers to daily steam cooking of 1-2 hours. In any case, if with a total hardness ≤ 8°dH there is still production of limescale, it is mandatory to treat the water in order to avoid limescale production. Unox recommends water treatment systems based on ion exchange resins. Water treatment systems based on polyphosphate are not allowed.

## Installation requirements

Installations must comply with all local electrical systems, particularly as for minimum wire gauge required for field connection, hydraulic and ventilation supply. Exhaust and fume analysis must be performed in case of gas ovens.

Register to DDC Service to access data and product specifications.  
[www.ddc.unox.com](http://www.ddc.unox.com)